

LED CANOPY LIGHT

SHP205 CANOPY

IP66



DIMENSIONS

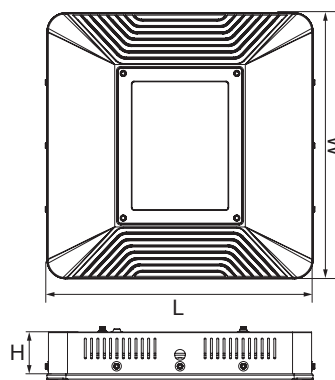
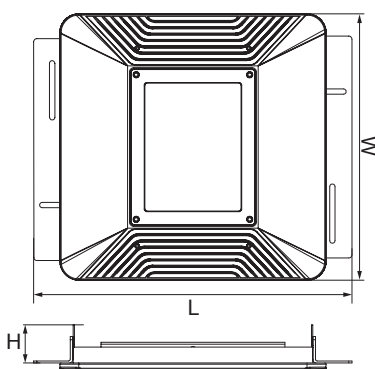

CONSTRUCTION

- Die-cast aluminium body
- Powder coated finish
- Clear tempered glass diffuser
- High efficiency SMD LED chips
- Built-in constant current non-dimmable LED driver
- High efficiency heat dissipation, light weight heatsink
- 120° beam angle

- Suits most traditional Canopy size (SHP205 RC)
- Symmetrical light distribution
- 300 mm 3 core rubber flex

IP RATING

- IP66 weatherproof

FITTING COLOUR

- White

Model No.	Input	Power	Lumen	CCT	Beam Angle	CRI	Cut Out	Dimensions L x W x H	Net Weight
SHP205/75RCS	240V	75W	9750lm	5000K	120°	>75	380 x 380 mm	502 x 420 x 60	7.5 kg
SHP205/75SM	240V	75W	9750lm	5000K	120°	>75	–	420 x 420 x 66	7.5 kg
SHP205/110RCS	240V	110W	14300lm	5000K	120°	>75	380 x 380 mm	502 x 420 x 60	7.5 kg
SHP205/110SM	240V	110W	14300lm	5000K	120°	>75	–	420 x 420 x 66	7.5 kg
SHP205/150RCS	240V	150W	19500lm	5000K	120°	>75	380 x 380 mm	502 x 420 x 60	7.5 kg
SHP205/150SM	240V	150W	19500lm	5000K	120°	>75	–	420 x 420 x 66	7.5 kg

IP66

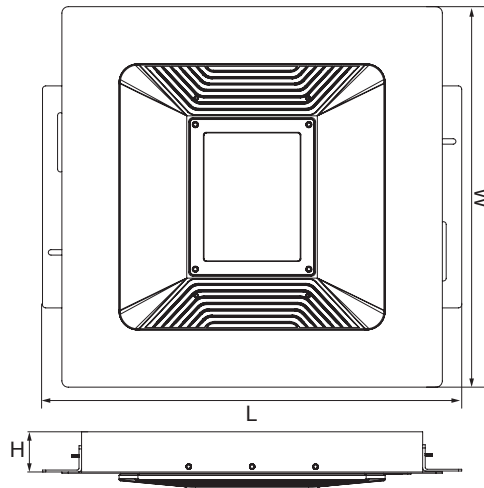

Model No.	Input	Power	Lumen	CCT	Beam Angle	CRI	Cut Out	Dimensions L x W x H	Net Weight
SHP205/75RC	240V	75W	9750lm	5000K	120°	>75	422 x 540 mm	600 x 600 x 66	12 kg
SHP205/110RC	240V	110W	14300lm	5000K	120°	>75	422 x 540 mm	600 x 600 x 66	12 kg
SHP205/150RC	240V	150W	19500lm	5000K	120°	>75	422 x 540 mm	600 x 600 x 66	12 kg

PHOTOMETRIC DATA Unit: cd C0/C180 — C90/C270

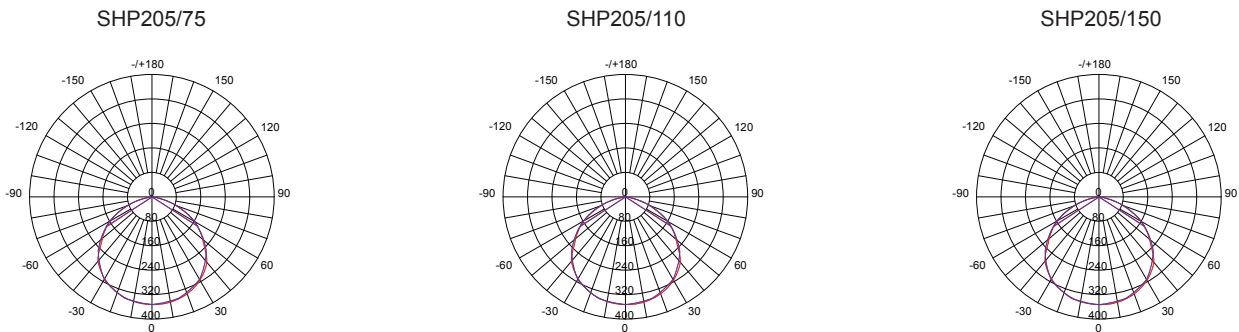

Specifications above are for reference only and may vary without prior notice